

# Speed Sensor Hall-Effect HA-N



- ▶ Max. frequency:  $\leq 4.2$  kHz
- ▶ Air gap: 0.4 to 1.5 mm
- ▶ Bore diameter: 10 mm
- ▶ Max. vibration:  $1,200 \text{ m/s}^2$  at 10 Hz to 2 kHz
- ▶ Weight w/o wire: 8 g

This sensor is designed for incremental measurement of rotational speed (e.g. camshaft, crankshaft or wheel speed). Due to the rotation of a ferromagnetic target wheel in front of the HA-N, the magnetic field is modulated at the place of the Hall probe. A Hall-effect sensor element with integrated signal conditioning circuit detects this change and generates a digital output signal.

The HA-N combines a robust sensing element with a lightweight aluminum housing that is well suited for motorsport use. The sensor element used was specifically selected for its resistance to demagnetization at high temperatures and is programmed for an active low output. This sensor element is approved for NASCAR competition as a camshaft speed sensor.

## Application

Application	Rotational speed
Max. frequency	$\leq 4.2$ kHz
Target wheel air gap AG	0.5 to 1.5 mm
Temperature range	-40 to $160^\circ\text{C}$
Output circuit	Open collector for 1 kOhm
Output type	Active low
External magnetic fields	$< 1 \text{ mT}$
Max. vibration	$1,200 \text{ m/s}^2$ at 10 Hz to 2 kHz

## Technical Specifications

### Mechanical Data

Weight w/ wire	13 g w/ 254 mm cable length and AS connector
----------------	--

	28.5 g w/ 1,000 mm cable length flying lead
Bore diameter	10 mm
Installation depth L2	14 mm
Tightening torque	6 Nm

### Electrical Data

Power supply	5 to 18 V
Current IS	5.6 to 18 mA

### Characteristic

Accuracy repeatability of the falling edge tooth	$< 4\%$ ( $\leq 4.2$ kHz)
Signal output	0.52 V to $V_s$

### Connectors and Wires

Sensor AS connector	
Connector	ASL606-05PA-HE
Mating connector	ASL006-05SA-HE
Pin 1	$V_s$
Pin 2	GND
Pin 3	Signal
Pin 4	Not used
Pin 5	Not used
Shrink sleeve	DR-25
Wire size	AWG 24
Wire length L	254 mm

Sensor Flying lead	
WHT/ORG	$V_s$
WHT/BLU	GND

Sensor Flying lead	
WHT	Signal
Shrink sleeve	DR-25
Wire size	AWG 24
Wire length L	1,000 mm

**Installation Notes**

The HA-N can be directly connected to most control units and data logging systems.  
 If a trigger wheel with different dimensions is used (see Environment), the technical function must be tested.

**Safety Note**

The sensor is not intended to be used for safety related applications without appropriate measures for signal validation in the application system.

**Legal Restrictions**

Due to embargo restrictions, sale of this product in Russia, Belarus, Iran, Syria, and North Korea is prohibited.

**Ordering Information**

**Speed Sensor Hall-Effect HA-N**  
 Sensor AS connector  
 Order number **F02U.V0U.714-01**

**Speed Sensor Hall-Effect HA-N**  
 Sensor Flying lead  
 Order number **F02U.V0U.714-90**

**Dimensions**

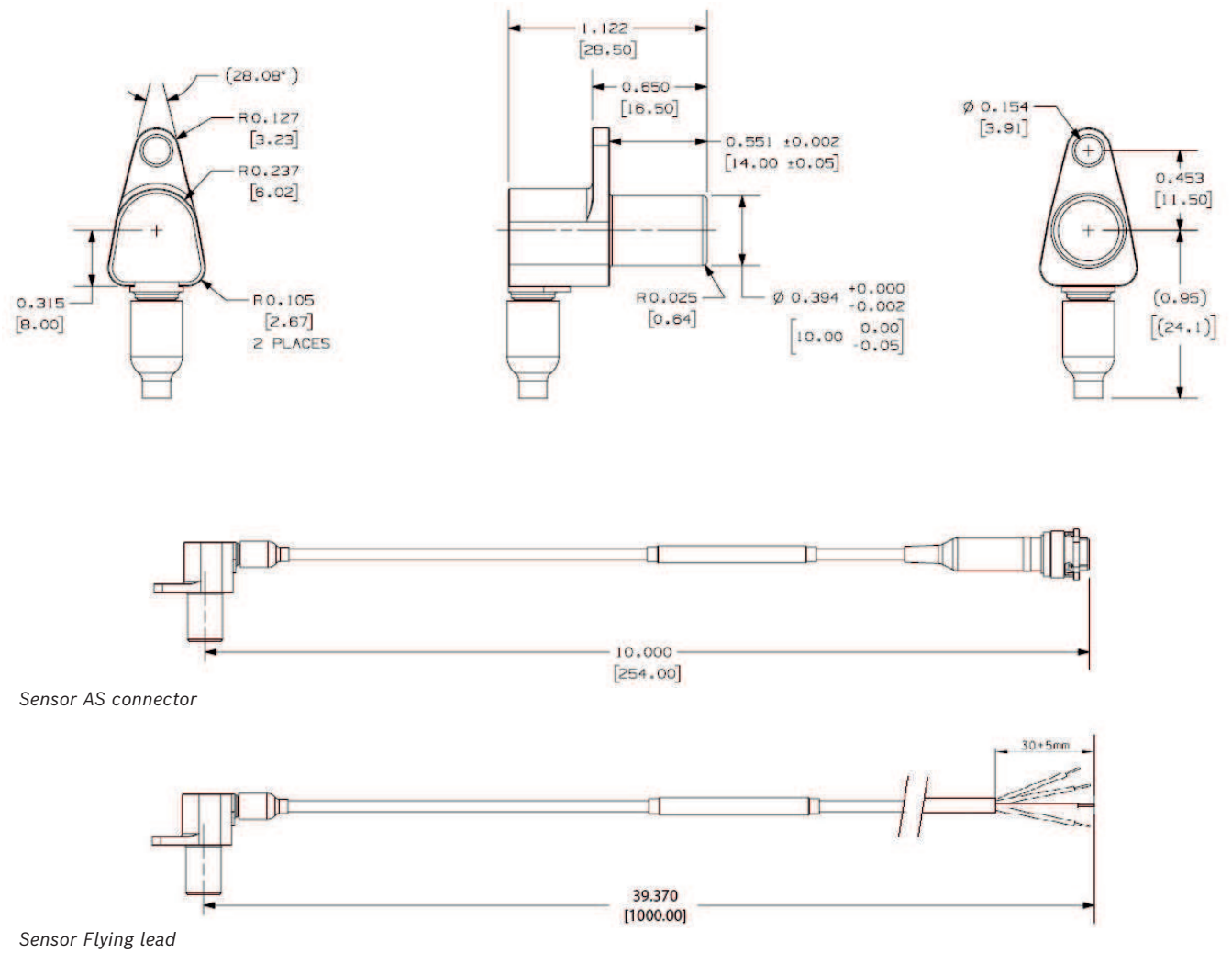

**Represented by:**

**Europe:**

Bosch Engineering GmbH  
Motorsport  
Robert-Bosch-Allee 1  
74232 Abstatt  
Germany  
Tel.: +49 7062 911 9101  
Fax: +49 7062 911 79104  
motorsport@bosch.com  
www.bosch-motorsport.de

**North America:**

Bosch Engineering North America  
Motorsport  
38000 Hills Tech Drive  
Farmington Hills, MI 48331-3417  
United States of America  
Tel.: +1 248 876 2977  
Fax: +1 248 876 7373  
motorsport@bosch.com  
www.bosch-motorsport.com

**Asia-Pacific:**

Bosch Engineering Japan K.K.  
Motorsports Department  
1-9-32 Nakagawa Chuo, Tsuzuki-ku  
Yokohama City  
Kanagawa Prefecture 224-8601  
Japan  
Tel.: +81 45 605 3032  
Fax: +81 45 605 3059  
www.bosch-motorsport.jp

**Australia, New Zealand and South**

**Africa:**  
Robert Bosch Pty. Ltd  
Motorsport  
1555 Centre Road  
Clayton, Victoria, 3168  
Australia  
Tel.: +61 (3) 9541 3901  
motor.sport@au.bosch.com